



Agile Unicorns

Erez Morabia

R&D Manager & Agile Coach

February 2022



The Bottom Line

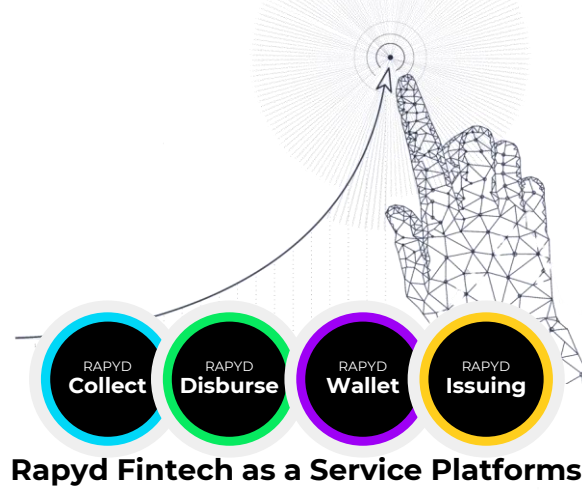

Rapyd Fintech as a Service Platforms

The Bottom Line

*We need to
move faster!*



CEO



The Bottom Line

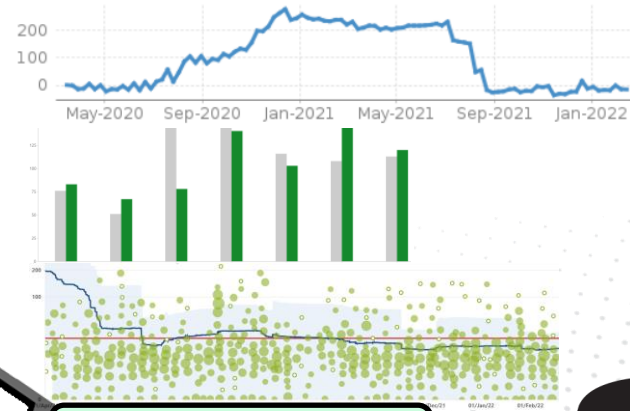

We need to move faster!

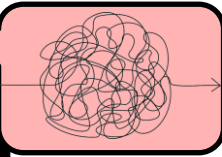

FAST FORWARD
10 months later...

- Delivery x1.6
- Cycle-Time x2.9
- Zero Defects Policy



How did the story start?



Observing 3 Months

How did the story start?



Observing 3 Months

Problem Statements

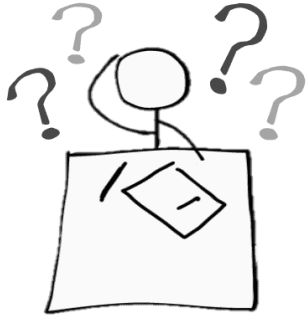

No data
Waste
Unclarity
Complexity
Miscommunication
Misalignment
Silos
No roadmap
Overcommitment
Dependencies
...

How did the story start?



Observing 3 Months

Problem Statements

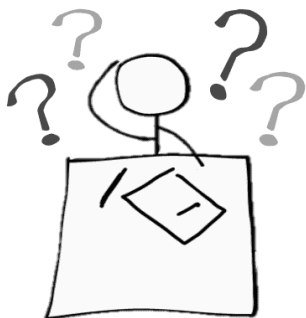

No data
Waste
Unclarity
Complexity
Miscommunication
Misalignment
Silos
No roadmap
Overcommitment
Dependencies
...

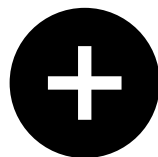

x5 delivery



Rapyd

How did the story start?



Observing 3 Months



WHAT IS THAT?

Problem Statements

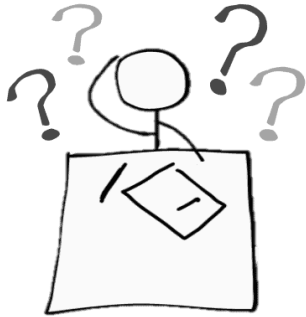

- No data
- Waste
- Unclearity
- Complexity
- Miscommunication
- Misalignment
- Silos
- No roadmap
- Overcommitment
- Dependencies
- ...

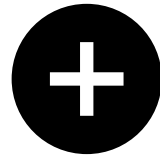

x5 delivery

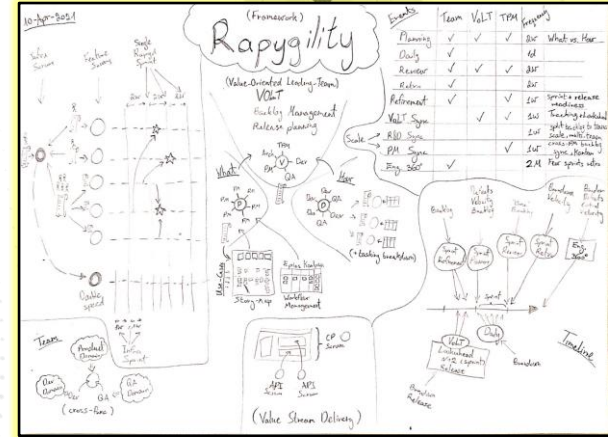

Rapygility

The Rapyd Model for Agility
(born 10-Apr-2021)



Rapyd

I can't do it alone!

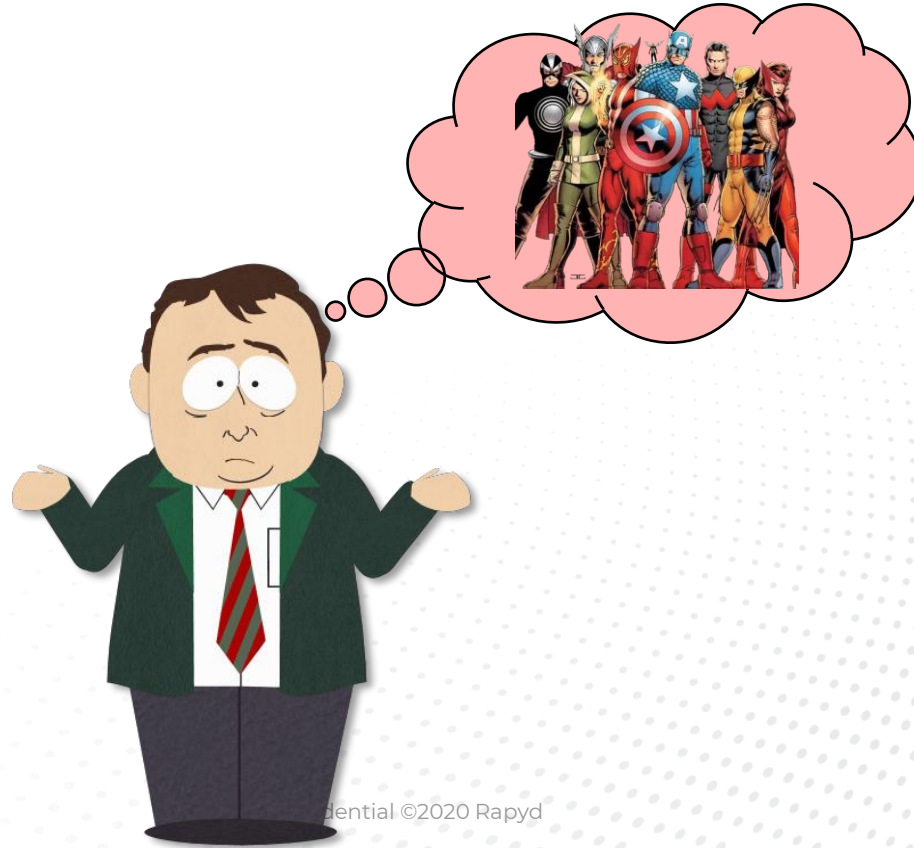

I can't do it alone!

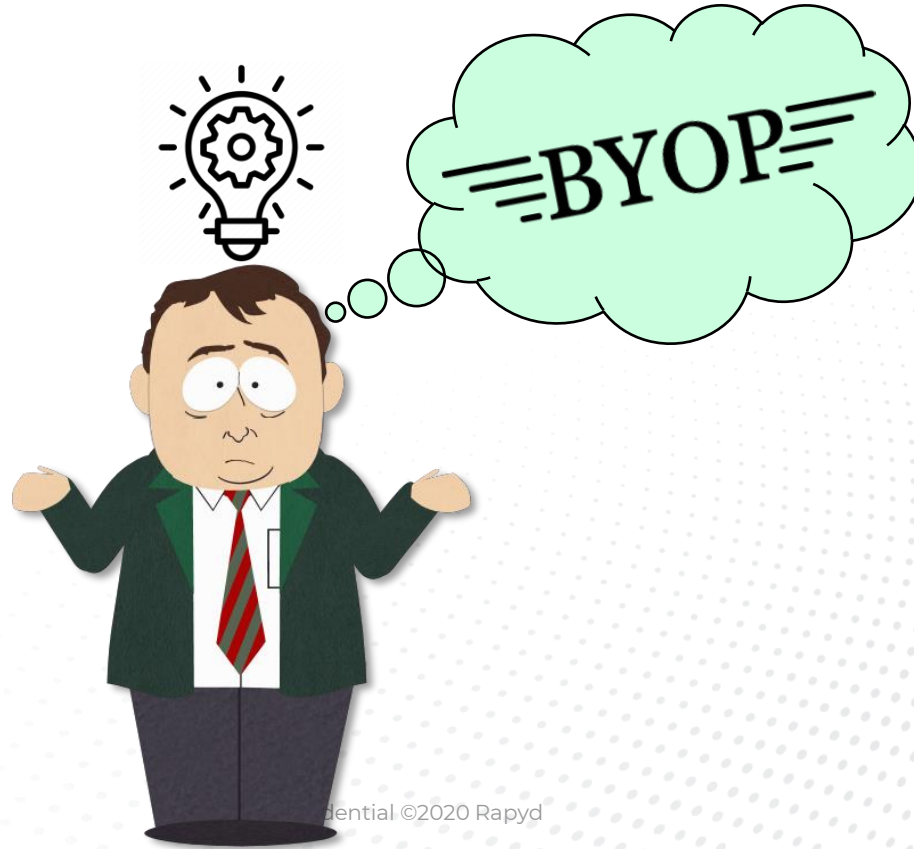

I can't do it alone!

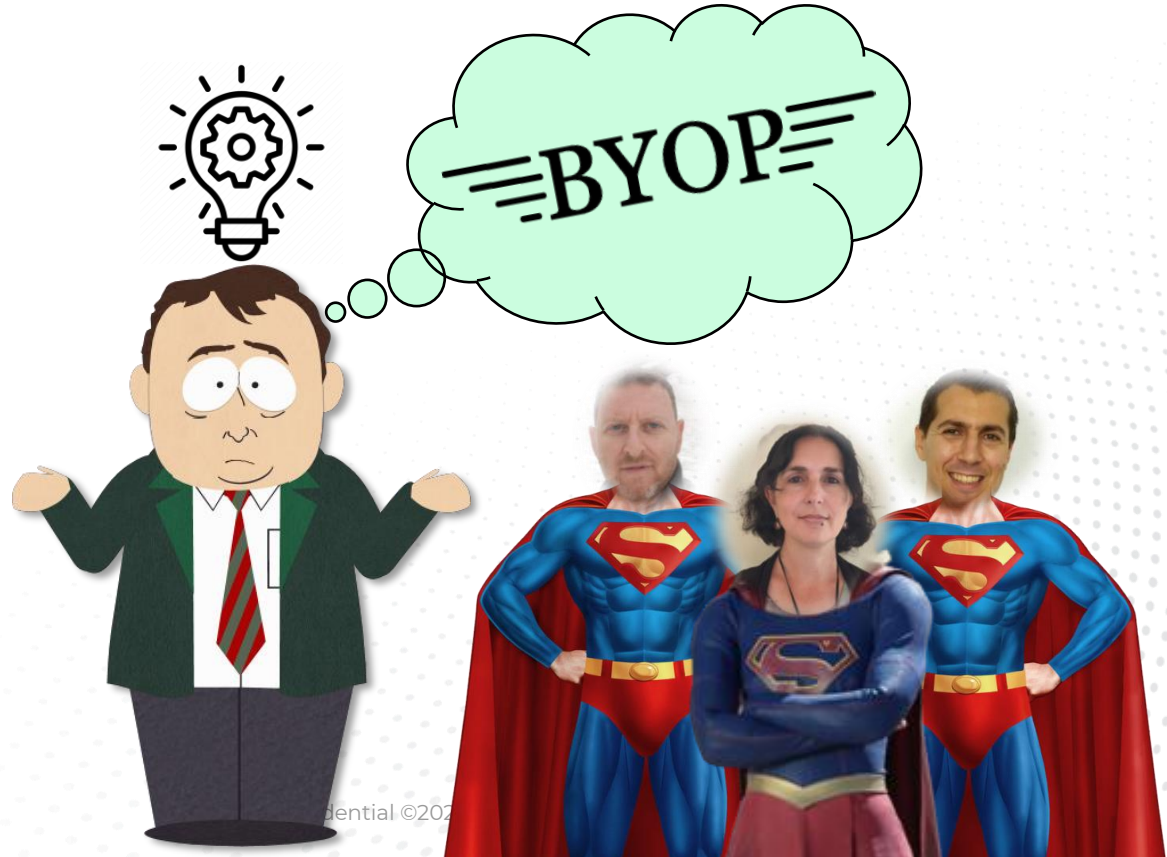

© 2021 Rapyd

Rapyd

Get it Going



"Failure is the
limit of my abilities"

**FIXED
MINDSET**

"I'm either good at it or I'm not"

"My abilities are unchanging"

"I don't like to be challenged" "I can either do it,
or I can't"

"My potential is predetermined"

"When I'm frustrated,
I give up"

"Feedback and criticism
are personal"

"I stick to what I know"

Rapyd

Get it Going

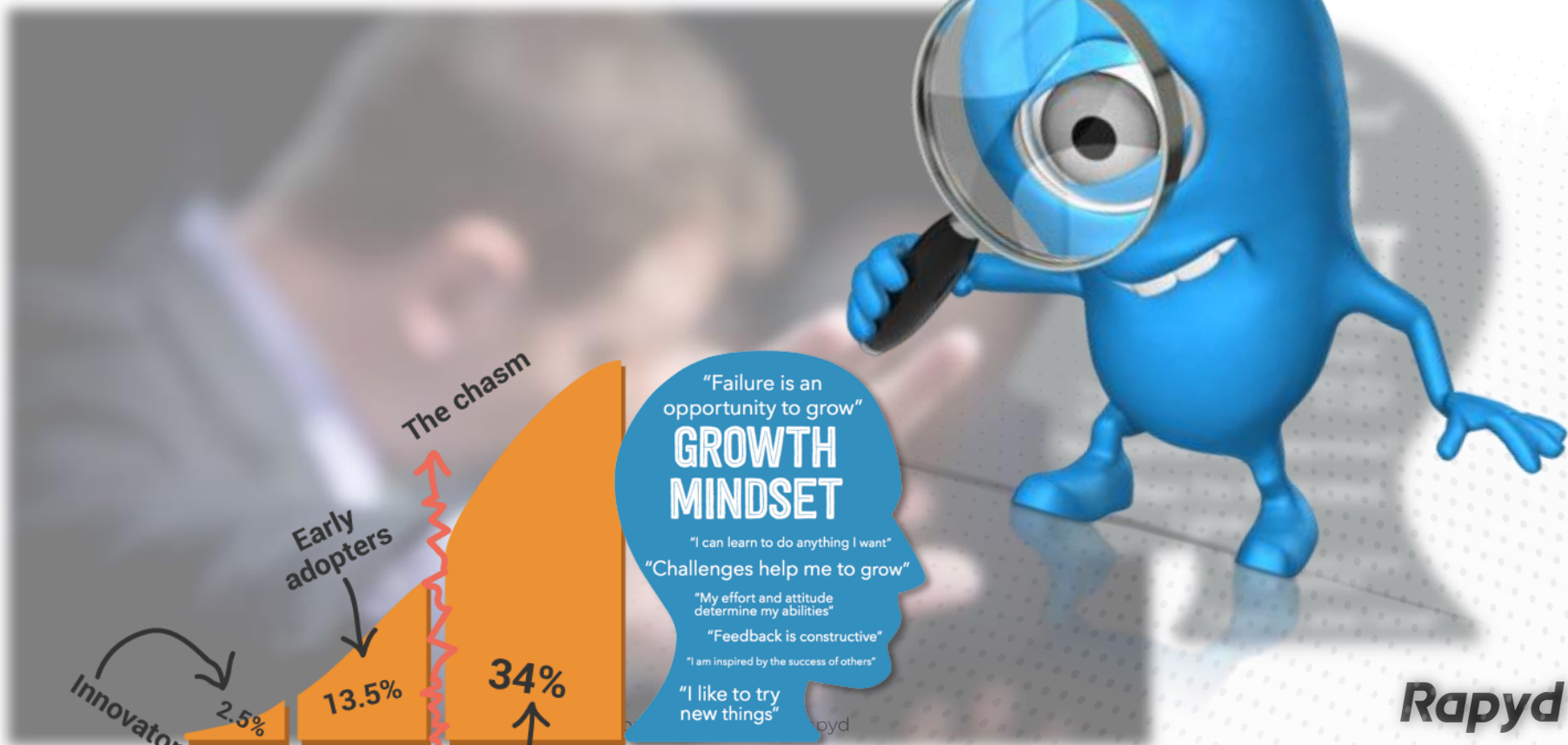

We Have Rapygility – Now What?

Product by Product

OR

All at Once

We Have Rapygility – Now What?

Product by Product

OR

All at Once

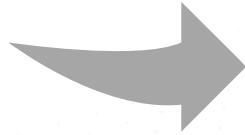

Jumping between Products

AND Sometimes

All at Once

We Have Rapygility – Now What?

Product by Product

OR

All at Once



Jumping between Products

AND Sometimes

All at Once

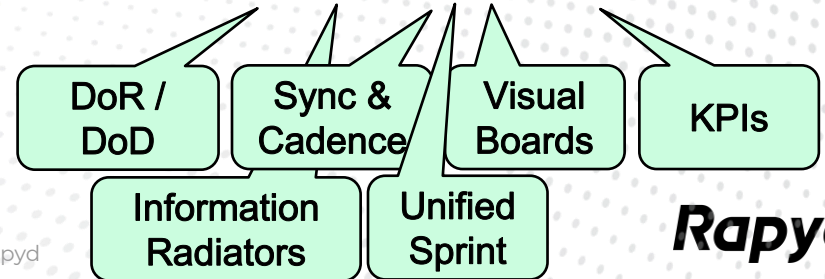

Rapyd

We Have Rapygility – Now What?

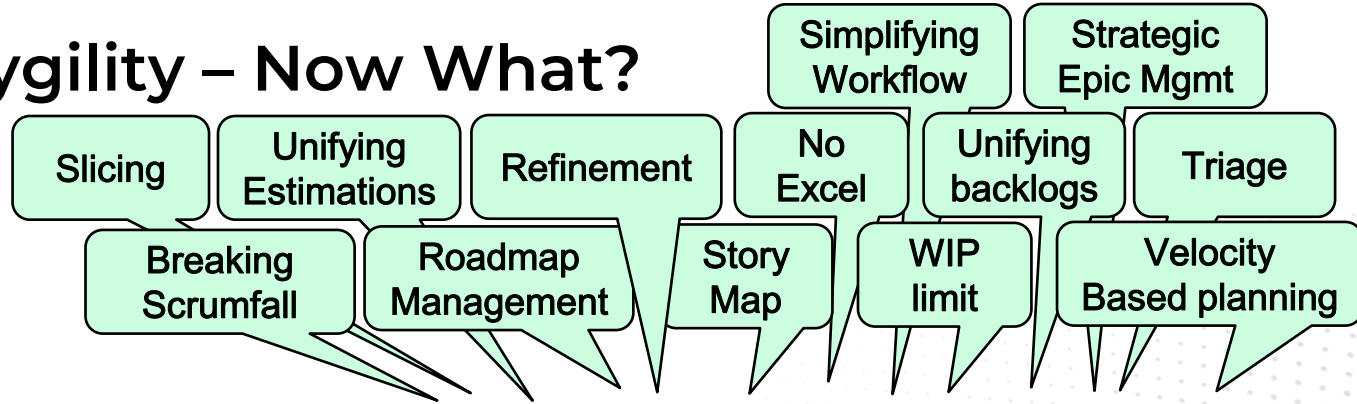

Product by Product

Jumping between Products

OR

All at Once

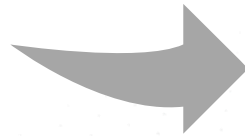

AND Sometimes

All at Once

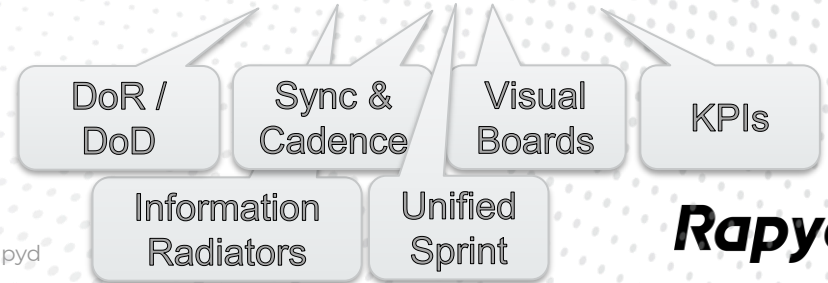

Rapyd

We Have Rapygility – Now What?

Finding Opportunities

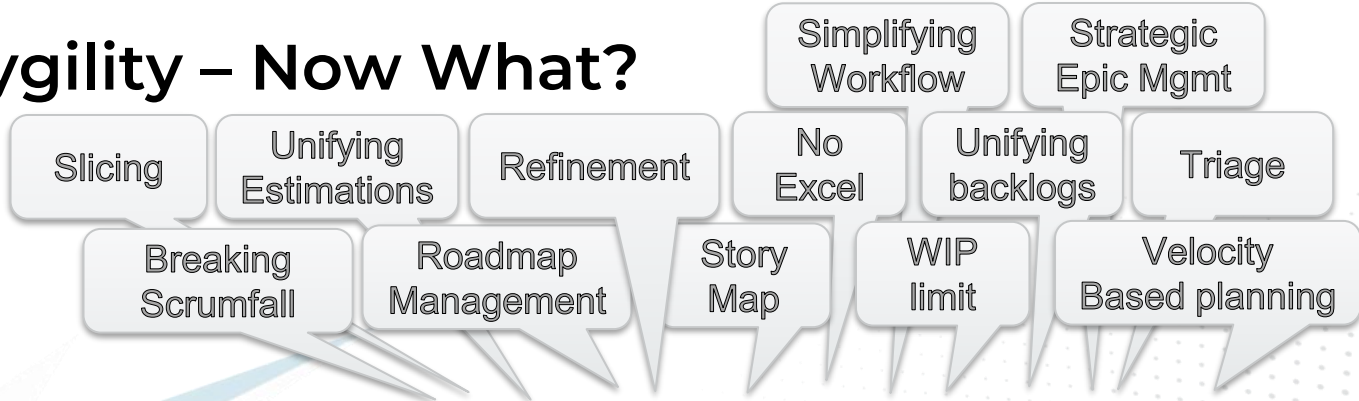

Jumping between Products

AND Sometimes

All at Once

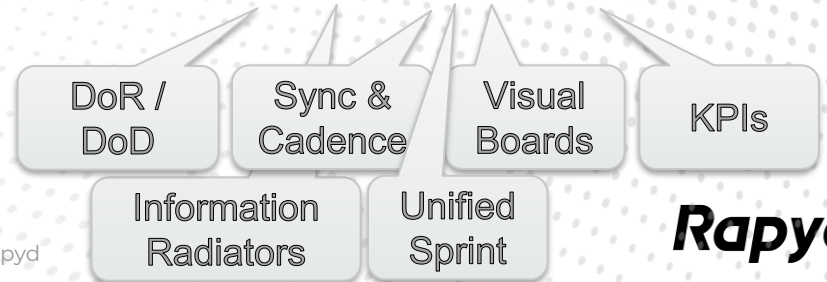

The Rapygility Path



Gather Data

 Jira Software

*Story vs. Task
What to Story-Point
Sprint vs. Release
Dev vs. QA
Boards
...*

The Rapygility Path

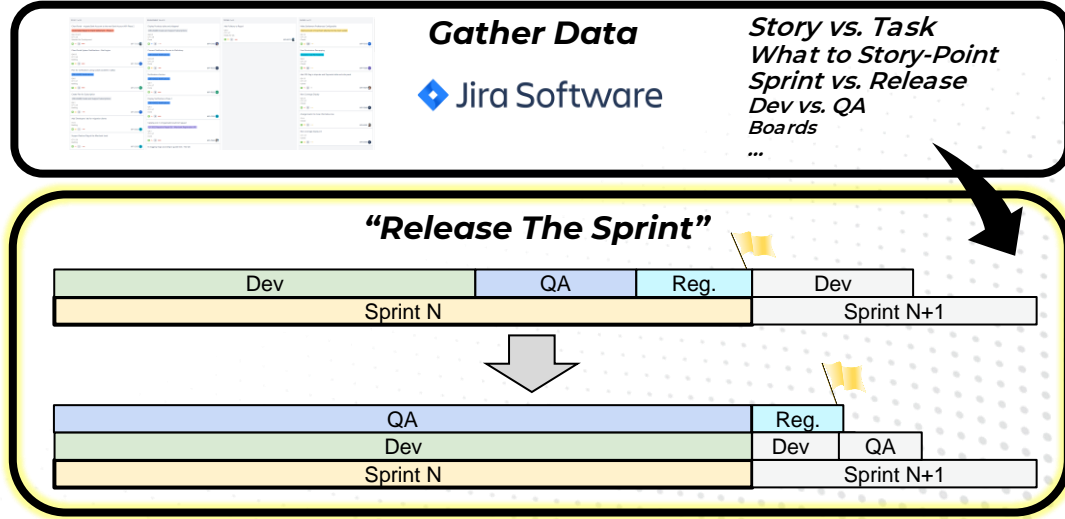

The Rapygility Path

Gather Data
Jira Software

*Story vs. Task
What to Story-Point
Sprint vs. Release
Dev vs. QA
Boards
...*

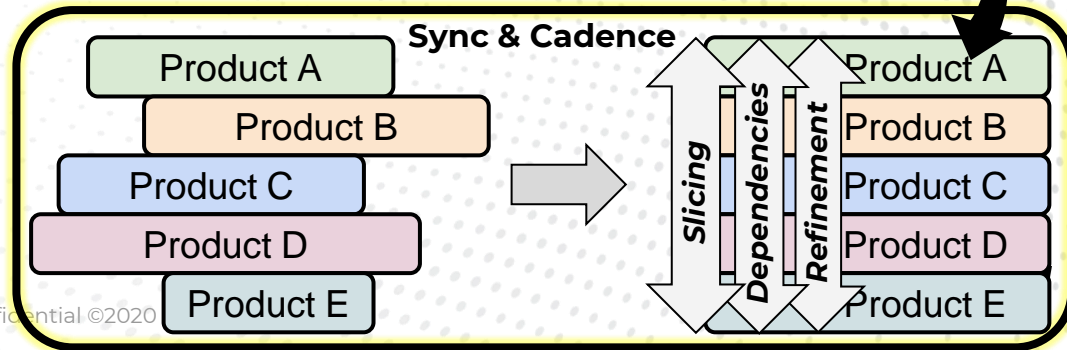
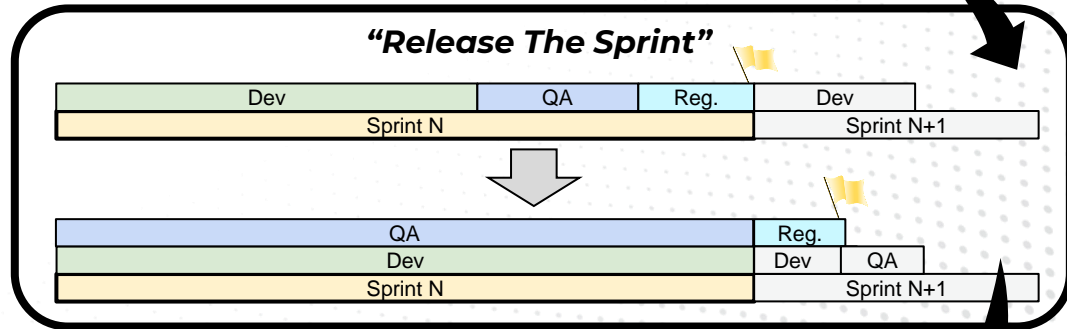

The Rapygility Path

Gather Data



◆ Jira Software

*Story vs. Task
What to Story-Point
Sprint vs. Release
Dev vs. QA
Boards
...*

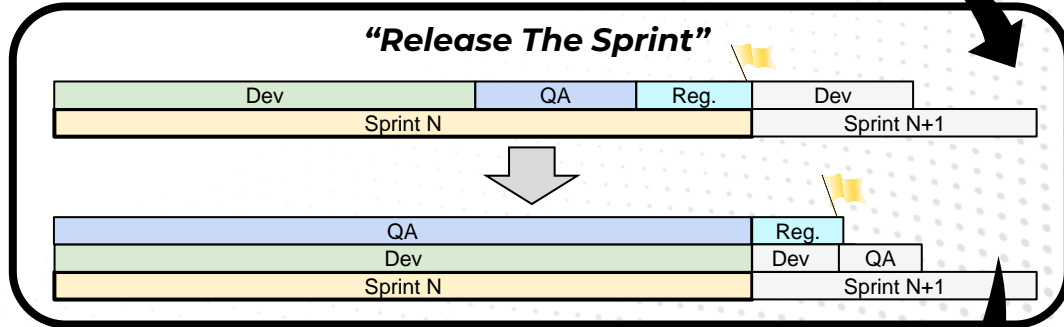

Product Focused KPIs

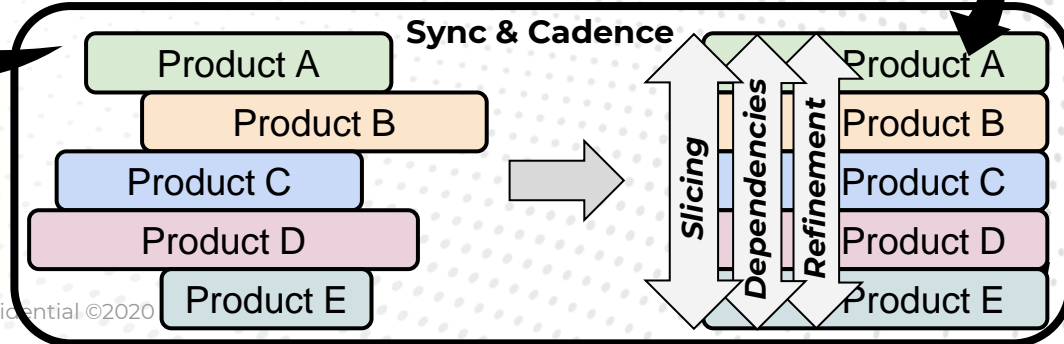
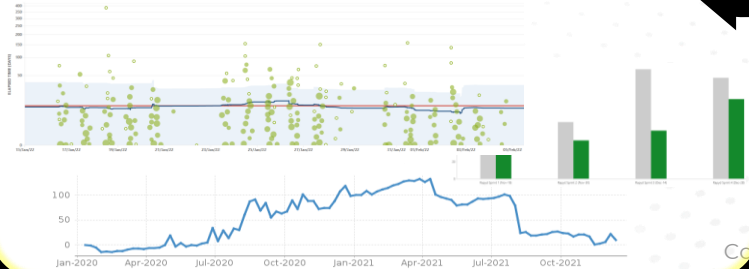

The Rapygility Path

Gather Data

 Jira Software

*Story vs. Task
 What to Story-Point
 Sprint vs. Release
 Dev vs. QA
 Boards*

Roadmap Workflow Management

20% → 50% → 80% → Deliver

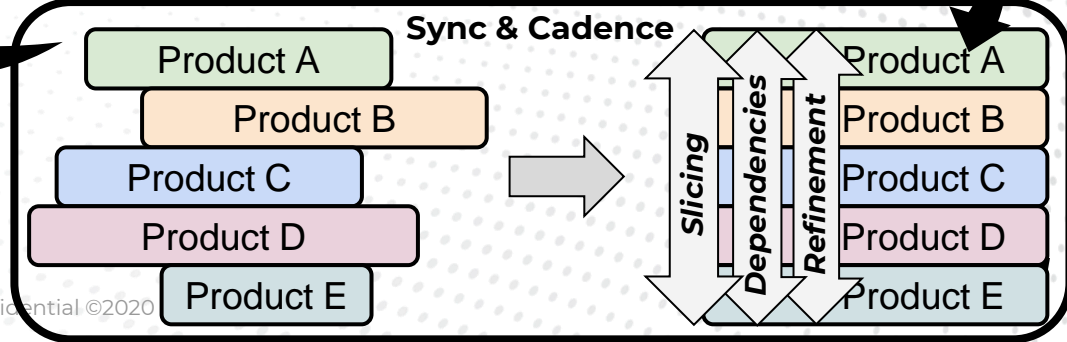
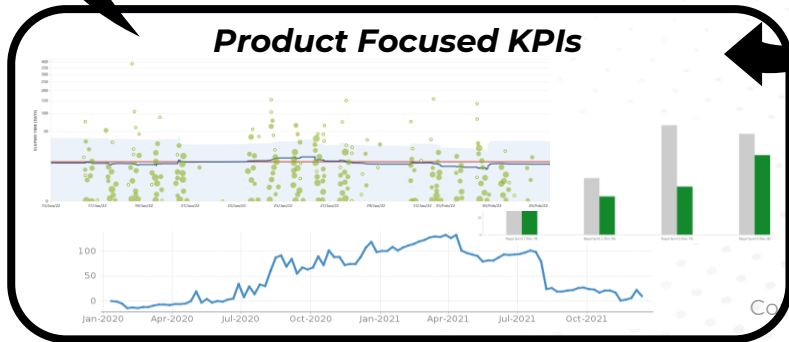
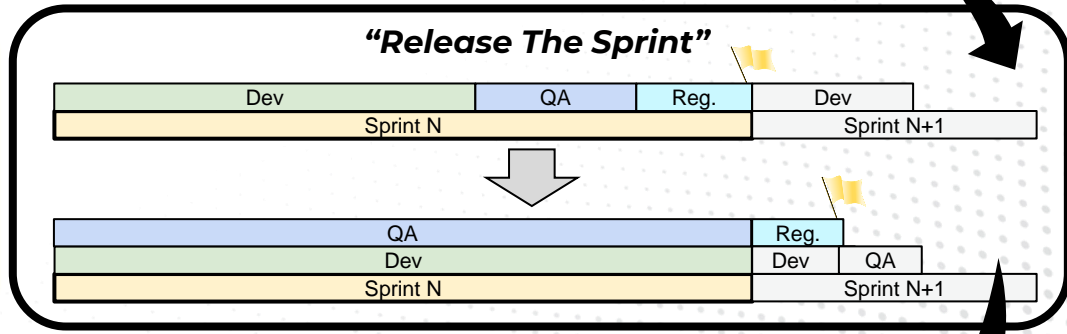
The Rapygility Path

Data Analytics **More Departments**

Sec **Ops** **IT**

PMO
PROJECT MANAGEMENT OFFICE

Gather Data

Jira Software

Story vs. Task
Sprint vs. Release
Dev vs. QA
Boards
...

Roadmap Workflow Management

→ 20% → 50% → 80% → Deliver

“Release The Sprint”

Product Focused KPIs

Sync & Cadence

Product A
Product B
Product C
Product D
Product E

Slicing
Dependencies
Refinement

You can change process, but minds are harder

THIS BOARD GIVES US
MAXIMUM VISABILITY

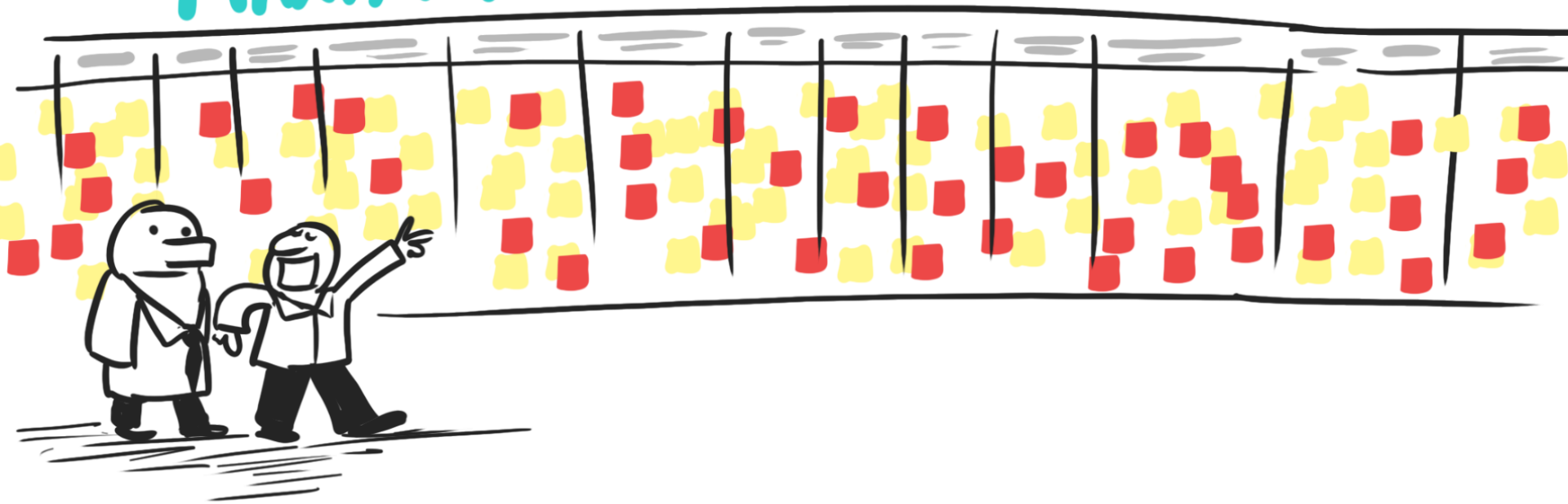

You can change process, but minds are harder

THIS BOARD GIVES US
MAXIMUM VISIBILITY



R&D Managers

Confidential ©2020 Rapyd

Rapyd

You can change process, but minds are harder

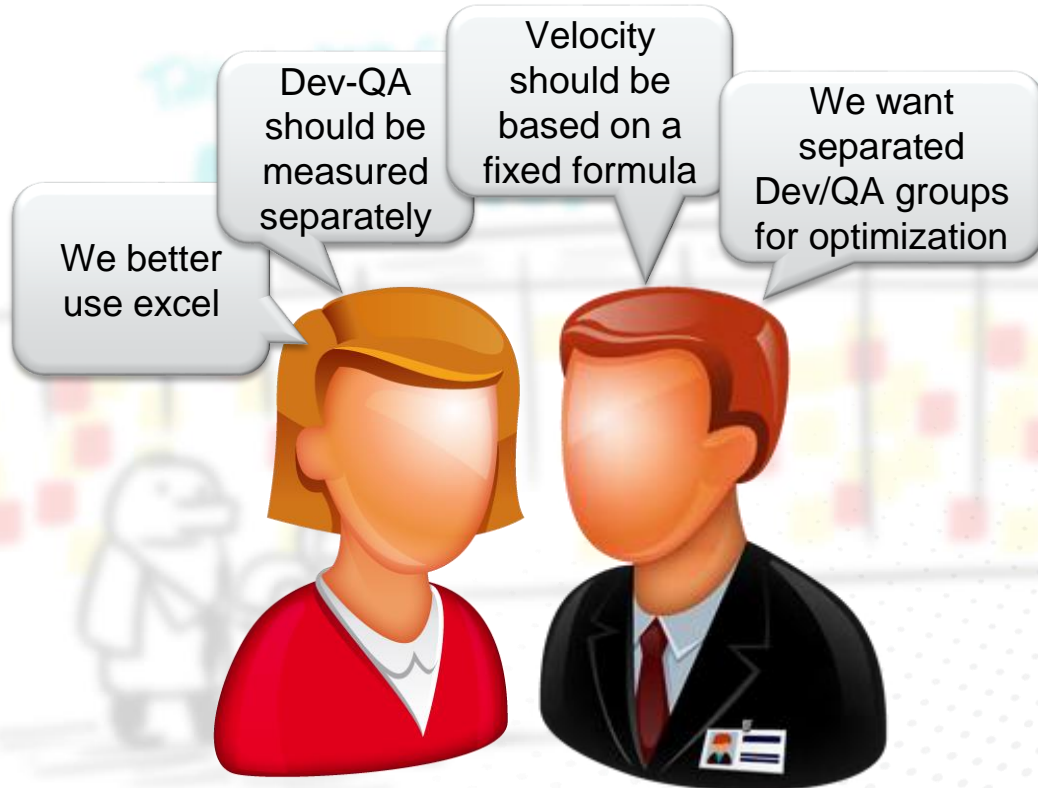

We better use excel

Dev-QA should be measured separately

Velocity should be based on a fixed formula

We want separated Dev/QA groups for optimization

R&D Managers

Confidential ©2020 Rapyd

Rapyd

You can change process, but minds are harder

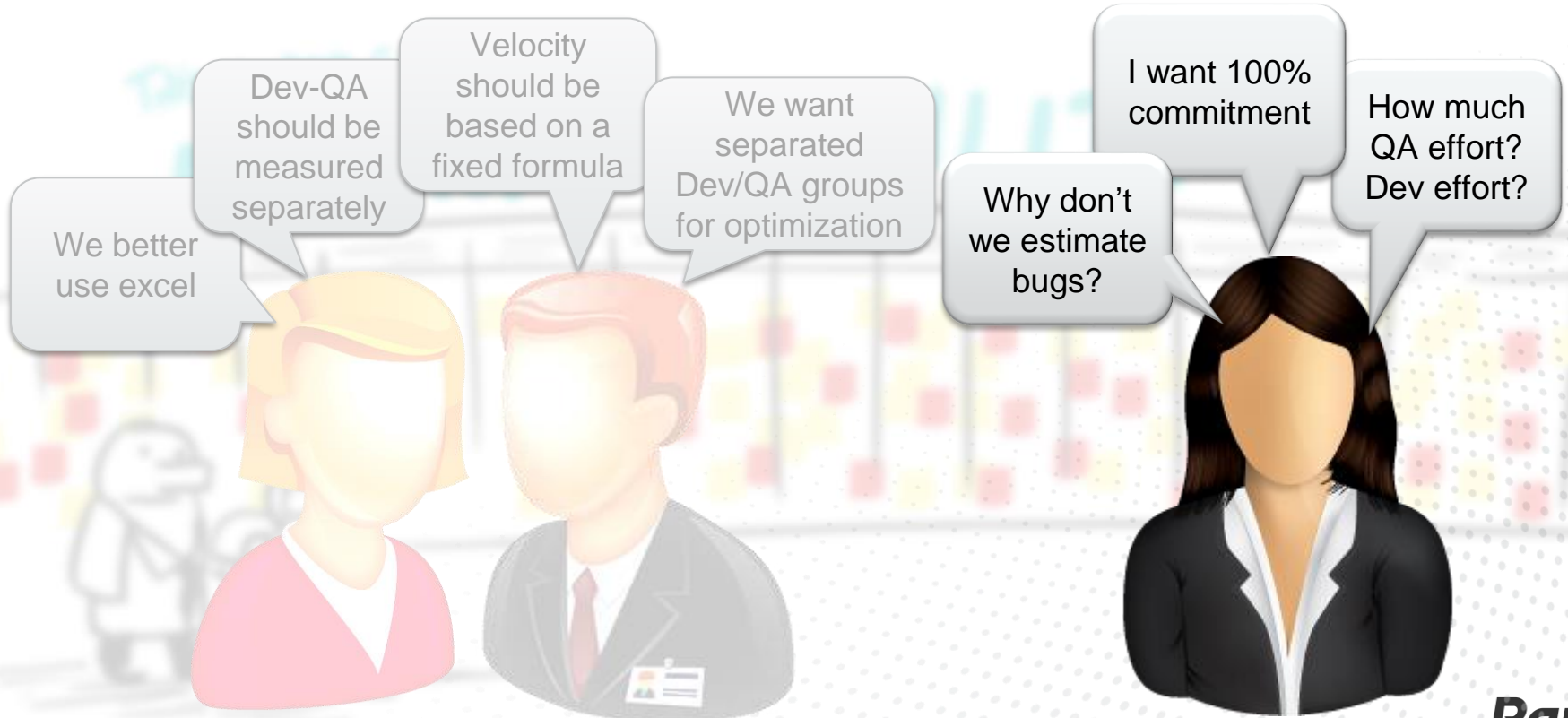

We better use excel

Dev-QA should be measured separately

Velocity should be based on a fixed formula

We want separated Dev/QA groups for optimization

Why don't we estimate bugs?

I want 100% commitment

How much QA effort? Dev effort?

R&D Managers

Confidential ©2020 Rapyd

Product Manager **Rapyd**

You can change process, but minds are harder

Dev-QA should be measured separately

We better use excel



100% commitment

How much QA effort? Dev effort?

Encouraging small failures...

Rapygility Uniqueness

Agile is the
ENGINE
not the
GOAL

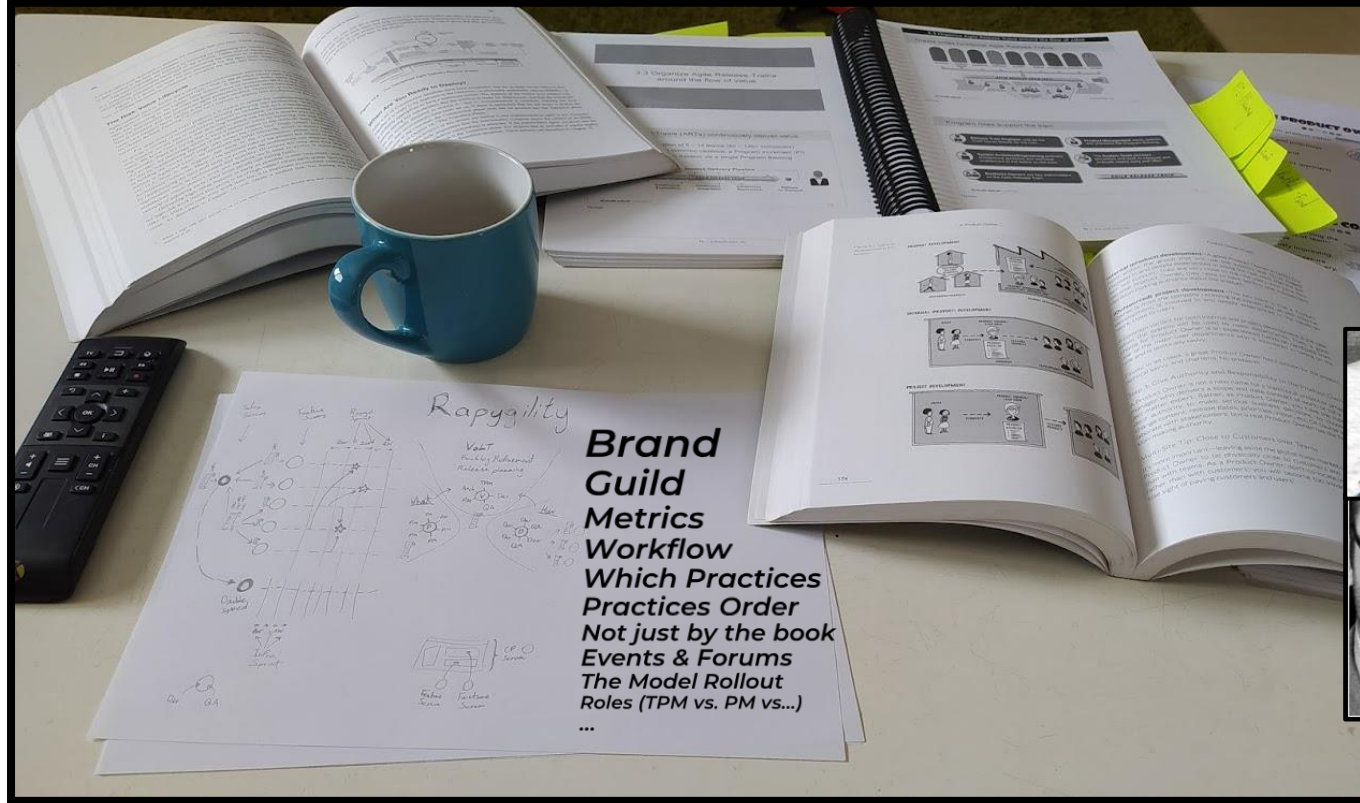
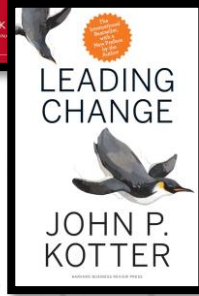
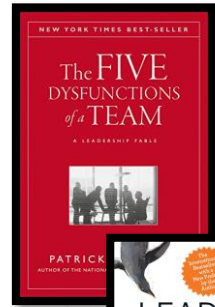

Rapyd



Agile Unicorns

Erez Morabia

R&D Manager & Agile Coach

February 2022

